

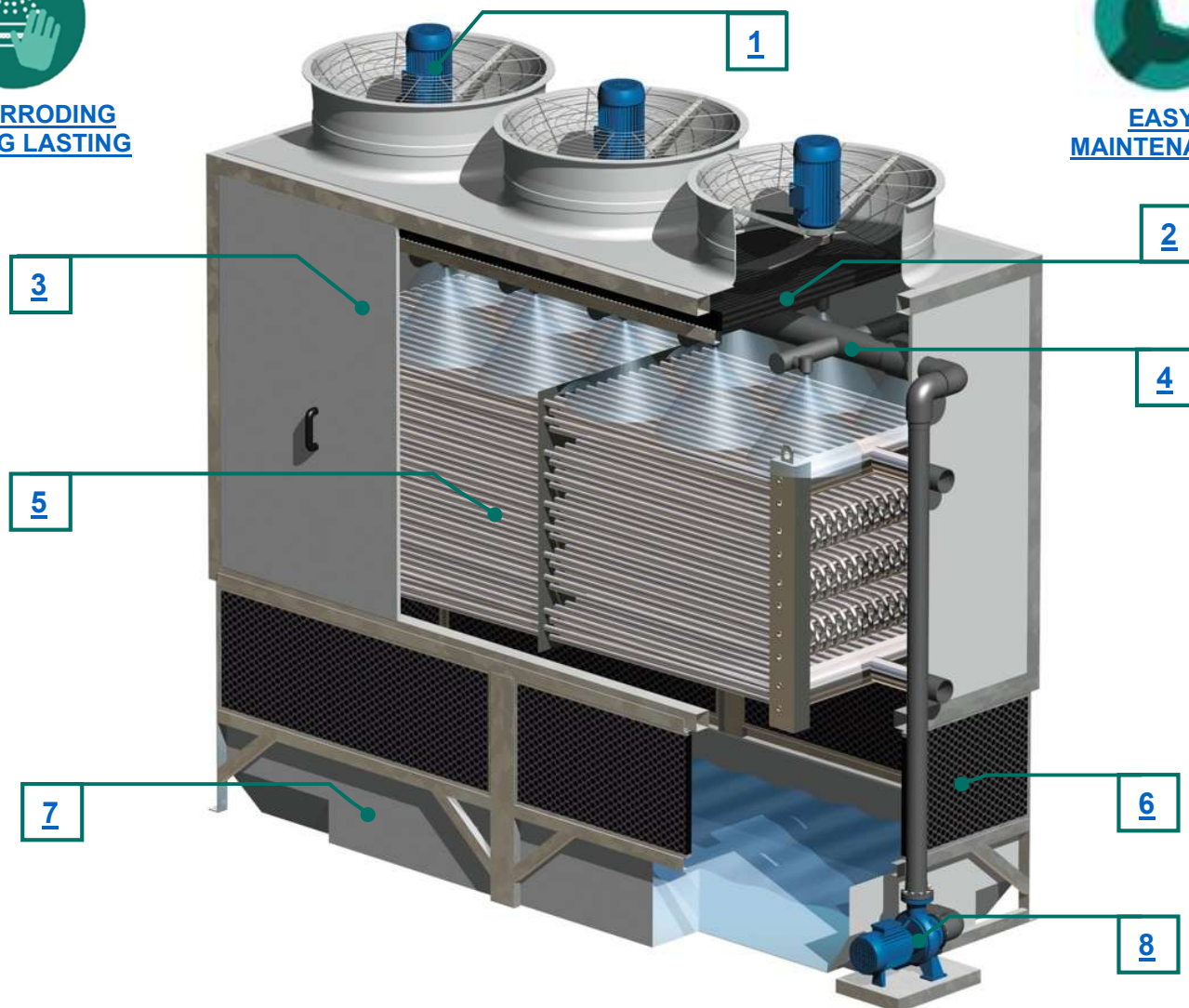

**NON-CORRODING
AND LONG LASTING**



**EASY
MAINTENANCE**



Closed Circuit Cooling Tower

Factory Assembled - Modular Compact Design

1	IP56 Motor(s) directly coupled to low energy and high efficiency fan
2	EUROVENT Certified High Efficiency DRIFT ELIMINATORS
3	Fibreglass reinforced polyester (FRP) sandwich casing panels and hot dip galvanised steel (HDGS) after fabrication perimeter frame
4	Water distribution system with non-clogging tangential Polypropylene (PP) nozzles for a full cone water distribution. Flanged water inlet connection
5	Cooling coil(s): high quality steel smooth tubes
6	Honeycomb air inlet louvers
7	Fibreglass reinforced polyester (FRP) water collection basin with sloping base and smooth internal finish with rounded corners for easy cleaning
8	Circulating pump
9	Factory assembled cooling tower, easy on-site installation

THEORY AND OPERATION OF EVAPORATIVE COOLING

In the primary circuit, incoming **hot water** enters the coils from the upper inlet while **cold water** leaves from the lower connection.

In the secondary circuit water is sprayed from the nozzles onto the coils. From opposite direction air will come and force a small part of the fluid to **evaporate**, causing the remaining water to be **cooled down which in turn cools the coils**. Air is sucked in by the fan and rejected from the top, recirculating water is collected in the basin.

The hydraulic separation from the primary to the secondary circuit allows to protect the cooling loop from pollution and impurities and run a glycol water mixture for icing protection.

Important values

Range: temperature difference between inlet and outlet

Approach: temperature difference between outlet and wet bulb. Must be minimum 2-3 °C.

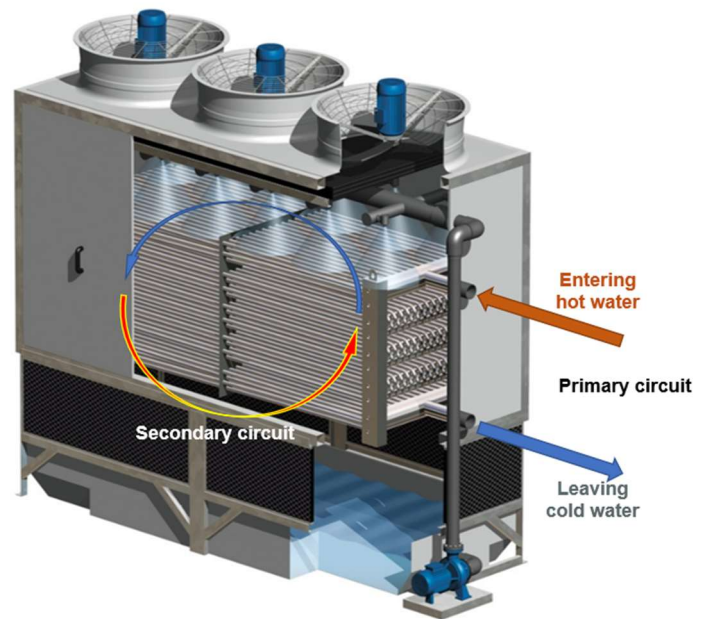

PRODUCT NOMENCLATURE

M		C		C		-		045		R		3		-		2		C		N		-		K1	
Product line																									
Dimension																									
m ²	1,9	020																							
m ²	2,9	030																							
m ²	3,5	035																							
m ²	4,5	045																							
m ²	5,5	055																							
m ²	6,9	070																							
m ²	8,4	085																							
m ²	10,7	110																							
m ²	12,9	130																							
m ²	16,2	160																							
m ²	20,8	210																							
m ²	16,8	170																							
m ²	21,4	220																							
m ²	25,7	260																							
Coil Type																									
Standard R																									
Twin pass T																									
Rows number																									
1 6 Rows																									
2 8 Rows																									
3 10 Rows																									
4 12 Rows																									
Fan																									
Pump																									
K0 Without pump																									
K1 One pump																									
K2 Two pumps																									
Fan noise																									
N Standard																									
S Silent																									
L Low noise																									
Fan type																									
A Axial AC version for models from 085 to 260																									
C Axial AC version for models from 020 to 070																									
Fan number																									
1																									
2																									
3																									
4																									

1. MOTOR FAN GROUP

UPPER SECTION(S) made of reinforced polyester (FRP) with gel-coat for UV-protection.

High efficiency directly coupled axial fan motor(s) assembly, designed to efficiently convey discharge air.

AXIAL FAN SYSTEM with the following features:

- one or more propeller fan(s) in aluminum or plastic, with blades connected to central aluminium hub directly coupled to the motor
- **IC 418** Sealed execution motor(s)
- Designed specifically for evaporative system minimum **IP55**
- **multi-voltage** (400/690/3/50), (50/60 Hertz), Class F insulation
- electric motor(s) suitable for operation with **frequency converter**.



SILENCED: several solutions to reduce noise levels:

- 12 or 16 poles motors to reduce fan speed and blades with special airfoil
- Water attenuators
- Air outlet silencers
- Air inlet silencers.

IMPORTANT SUGGESTION (especially in case of 12 poles motors): it is recommended to start the motor/s by means of a “soft-starter” or with frequency converter.



2. DRIFT ELIMINATORS

EUROVENT Certified High Efficiency DRIFT ELIMINATORS made of polypropylene (PP) sheets, thermoformed under vacuum and welded together to form panels of such shape and size as to guarantee maximum efficiency of droplet separation from the airflow induced by the fan, substantially reducing drift water.

3. WATER DISTRIBUTION SYSTEM

WATER DISTRIBUTION SYSTEM connected to the water recirculation pump, is entirely made in PVC. Consisting of a main header with flanged water inlet according to UNI-EN-1092-1- PN 10 and side branches where static type, non-clogging, axial, spray nozzles are fixed.

Such system guarantees optimal water spraying over the whole coil surface.

Spray nozzles are in polypropylene, with full-cone spraying angle of 120°.



4. STRUCTURE AND CASING

CASING walls consisting of 22 mm thick polyester resin sandwich panels reinforced with fibreglass and coloured with paste gel-coat for UV-protection. Seal between the load bearing structure and the panels is guaranteed by a special bituminous sealing gasket.

NUTS AND BOLTS in stainless steel **AISI 304**

Optional: **Man-sized access door(s)** (each 720x520mm) in FRP sandwich panel in a HDGS (after fabrication) frame to allow easy inspection or access to the inside of the tower.

Optional: **Totally removable side-wall(s)**, to simplify routine maintenance operations to the tower internals.

Optional:

- **STAINLESS STEEL METAL STRUCTURE** in AISI 304 or AISI 316
- **C5/CX COATED STRUCTURE**

in case of aggressive water or environment.



5. COOLING COIL(S)

COOLING COIL(S) consisting of high quality steel smooth tubes, supported by a frame made of HDGS profiles: the whole assembly is hot-dip galvanised after fabrication.

During manufacturing process, every circuit is carefully checked and air-pressure tested under water. A final pressure test is performed on the entire coil, after manufacturing.

Coil geometry is designed to ensure complete wetting of the heat exchange surface and to optimize external air-water contact, to maximize the thermal cooling capacity.

Moreover tube sloping ensures fluid's complete water discharge through the outlet connections, placed in line with the bottom of the outlet header to avoid "dead zones".

Optional:

- **STAINLESS STEEL COILS** (AISI 304 or AISI 316)
- **HERESITE COATED COILS**

in case of aggressive water or environment.



6. HONEYCOMB LOUVERS

HONEYCOMB LOUVERS in PP or PVC, to limit the basin's exposure to sunlight and dirt, thus reducing the risk of biological proliferation.



7. WATER COLLECTION BASIN

WATER COLLECTION BASIN is entirely made of fibreglass reinforced polyester (FRP).

SLOPING BASE with **ROUNDED CORNERS** for ease of cleaning and reduced risk of biological growth. Supplied with **drain, make-up and overflow connections**.



8. CIRCULATING PUMP

WATER CIRCULATING PUMP for the secondary spray-water circuit, connected to the water distribution system, external to the coils. The pump is fixed to the cooling tower support structure and is equipped with PVC piping.



9. TRANSPORT & INSTALLATION

MCC is a **factory assembled** cooling tower, designed to be transported with standard trucks in three pieces:

- Basin and lower structure (1)
- Connection pipe (2)
- Body (3).

The cooling tower is designed for the easiest possible on-site installation operations, consisting in positioning and fixing body on top of the structure.

Water connections can be threaded or flanged, and the electric connection are limited to the electrical junction box or switch box (optional), positioned on the side wall of the unit.

- A. Tower body from MCC 020 to MCC 070
- B. Tower body from MCC 085 to MCC 160
- C. Basin and lower structure

The secondary water recirculation circuit must be closed by installing the pipe, supplied separately, between the spraying pump and the connection to the water distribution piping. The connections between tank, water distribution and pump are made using reinforced rubber pipe and hose clamps.

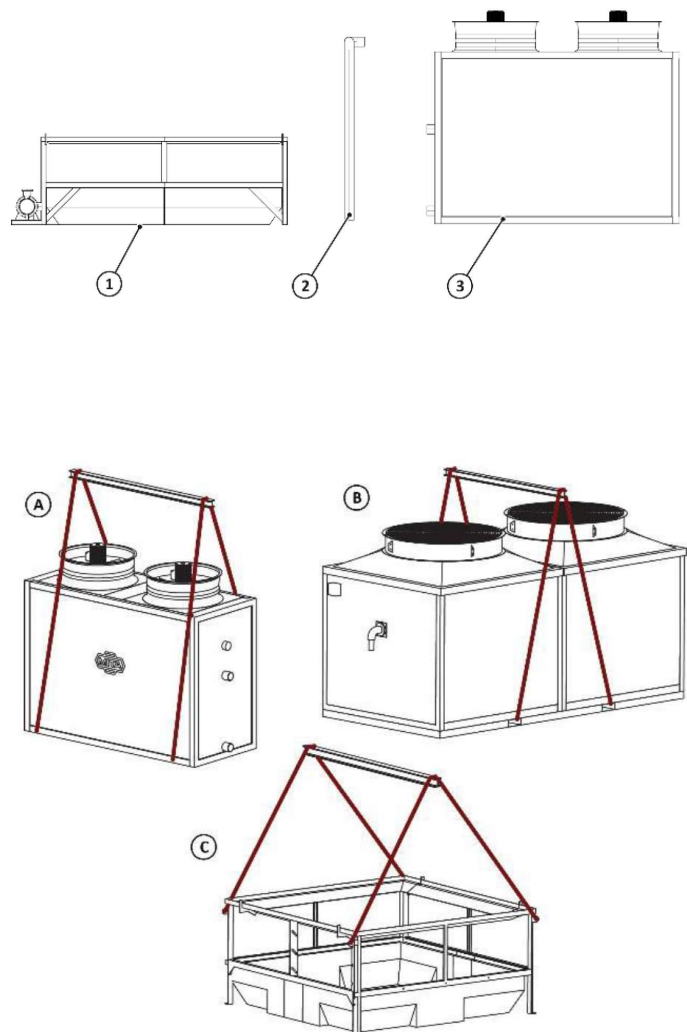

Supply of the tower is limited to the parts listed above. Building and electrical works, pumps, collectors external to the tower, valves, hoisting gear and any scaffolding and labour are therefore excluded. Accessories and/or constructive variants are available on request. MITA Cooling Technologies S.r.l. may carry out constructional improvements without notice. Images for illustration purposes only.